



## WATER TECHNIX VORTEX ECO PUMP

The Water TechniX Vortex ECO Pumps have been designed with industry leading components to be robust and reliable. Utilizing best in class technology, the Vortex ECO Pump delivers superior pumping performance coupled with optimum energy efficiency for maximum savings. With a approved 5 star energy rating, the Vortex pump is truly going to save energy.

### Features:

- Engineered with high quality stainless steel bearings & a heavy duty viton mechanical seal
- 100% copper wound, variable speed, totally enclosed fan-cooled motor
- High flow ports with screw on unions to suit 50mm Inner diameter, 60mm outer diameter pipe
- Ergonomic cam-lock clear lid with easy to open handles
- Full variable speed to enable custom energy efficiency based on application
- Whisper quiet at normal operation at 60dBa, and ultra quiet on low speed



- One touch interface controller for easy speed setting changes
- Achieve up to 80% energy reductions in operating costs and reduce carbon emissions
- Low-maintenance, large basket that handles all debris with a breeze
- Recommended for Sand Filters or large capacity Cartridge filters
- Compatible with salt, chlorine and magnesium pools
- 240 Volts, 50Hz single phase 10amp Australian lead to connect directly into power
- Impact resistant, anti-corrosive, UV resistant ABS housing that is built to last
- Sleek elevated design to avoid moisture ingress
- IPX4 Water and weather rated
- Retro fits Astral CTX, P320 and Davey DSF pumps

The Vortex pump is an energy-efficient pump that features full variable speed, allowing to increase and decrease the speed of the motor revolutions for all situations without losing pool filtration efficiency. Lower speeds are best for energy efficiency, allowing you to filter your pool and circulate your chemicals all day, every day. For cleaning your pool with a manual vacuum or an automatic pool cleaner, the mid flow setting is the way to go. The only time that you would need to switch it to high is for those days with high bather loads or backwashing.

Compared to conventional single speed pumps, the Water TechniX Vortex pump will save between \$600 and \$1,000 every year in operating costs and runs at whisper quiet 60dB, the equivalent of a hushed human conversation. This savings alone means the pump will basically pay for itself in under a year!

Hydraulically designed with a large basket and easy to open lid keeps maintenance a breeze. Couple that with a 100% copper wound motor to improve the performance and reduce energy consumption, you've got yourself a no-brainer pool pump.

With a sleek elevated design and compact footprint it's a simple DIY Installation and will retrofit into existing pipework with minimal plumbing changes. The pump comes with easy fit 40mm or 50mm unions which are suitable for in-ground and plunge pools between 60,000L - 120,000L.

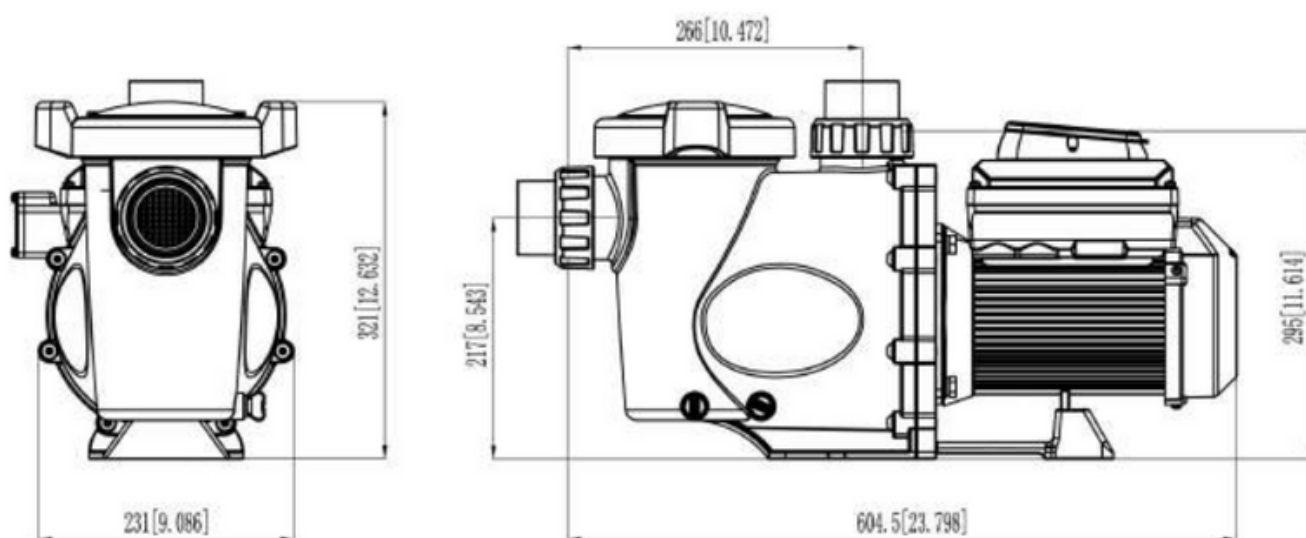

#### **Vortex Pump specifics:**

- Compact design for tight areas - 60cm Long x 23cm Wide
- Max flow rate 475 L/min @ 3450 RPM
- Low flow rate 55L/min @ 450 RPM
- Suits pools up to 60,000L - 120,000L

#### **Whats in the box:**

- 1 x Water TechniX Vortex pump
- 2 x Easy fit 50mm unions
- 1 x Instruction manual

#### **Warranty:**

- 2 year warranty on manufacturer faults and defects
- 12 months on mechanical seal and bearings

**Exclusively owned by Mr Pool Man**

[support@mrpoolman.com.au](mailto:support@mrpoolman.com.au)

1300 511 901

[mrpoolman.com.au](http://mrpoolman.com.au)